

COAXIAL COUPLERS

INDEX

1 – MANUFACTURERS CODE NUMBERS	3
2 – FACILITIES AND CUSTOMERS	4
3 – GENERAL SPECIFICATIONS	6
3.1 Environmental characteristics	
3.2 Mechanical characteristics, materials and finishes	
3.3 Manufacturing and quality assurance	
4 – SELECTION GUIDE	8
5 – CATALOG TERMS AND CHARACTERISTICS OF TECHNICAL DATA	10
6 – PRODUCTS	14
6.1 3 dB 90° hybrid SMA coaxial couplers	
6.2 Flat response unidirectional coaxial couplers	
6.3 3 dB 90° hybrid high power coaxial couplers	
6.4 Unidirectional high power coaxial couplers	
7 – SPECIAL COUPLER DESIGNS AND CONFIGURATIONS	23

1 – MANUFACTURERS CODE NUMBERS

RADIALL, Military supply code manufacturer F0503 and F6507, is a qualified supplier of coaxial couplers under military specifications, as well as other microwave components, to various governmental agencies. Radiall Quality Assurance is fully approved by NATO (AQAP4). The following is a partial listing of national stock numbers which RADIALL has provided to the French Ministry of Defence.

MSCM	RADIALL Part number	NSN
F657	R 432 134	5985 14 313 7794
	R 432 171	5985 14 309 9409
	R 432 271	5985 14 309 9410
	R 432 274	5985 14 324 2002
	R 432 275	5985 14 367 8714
	R 432 371	5985 14 300 2509
	R 432 432	5985 14 327 7287
	R 432 433	5985 14 315 5751
	R 432 464	5985 14 356 8349
	R 432 472	5985 14 337 0311
	R 432 531	5985 14 350 6498
	R 432 533	5985 14 374 8394
	R 432 534	5985 14 353 7761
	R 432 631	5985 14 322 4824
	R 432 632	5985 14 331 9482
	R 432 634	5985 14 318 2466
	R 432 763	5985 14 297 5020
	R 432 951	5985 14 380 7448
	R 432 464	5985 14 386 8557
	R 432 523	5985 14 376 0750
R 432 611	5985 14 421 9734	
R 432 613	5985 14 418 7019	
R 432 723	5985 14 362 3159	

COAXIAL COUPLERS

2 – FACILITIES AND CUSTOMERS

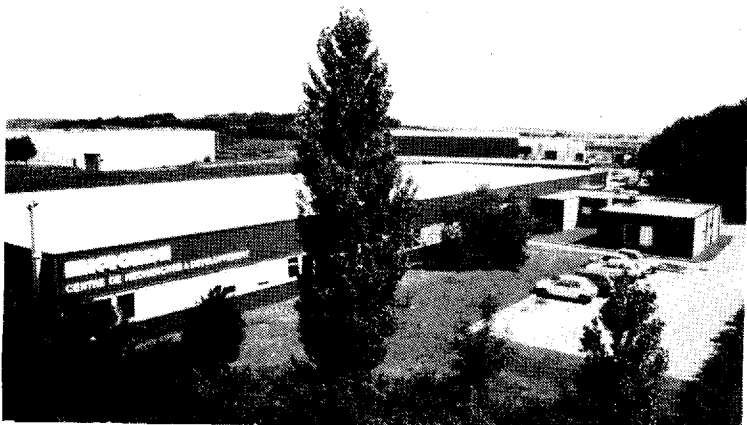

RADIALL Microwave dept. facility

Thanks to RADIALL's long experience, recognized quality, innovation, and sustained high investment in research, development, and production efficiency, it has become the **number one European manufacturer of coaxial connectors**. RADIALL has therefore risen to the forefront in the field of microwave components.

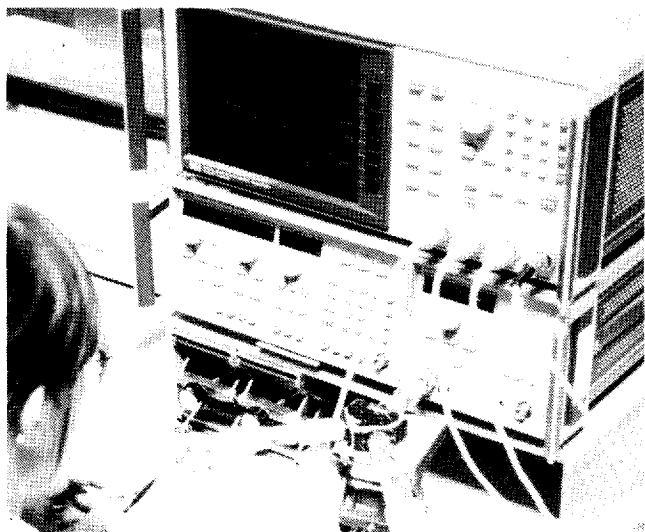

Microwave components testing

Located at l'Isle d'Abeau (near Lyon) in the heart of the Rhone/Alpes region, crossroads of French high technology, RADIALL's microwave department has specialized for some 25 years in the design and manufacture of passive microwave components

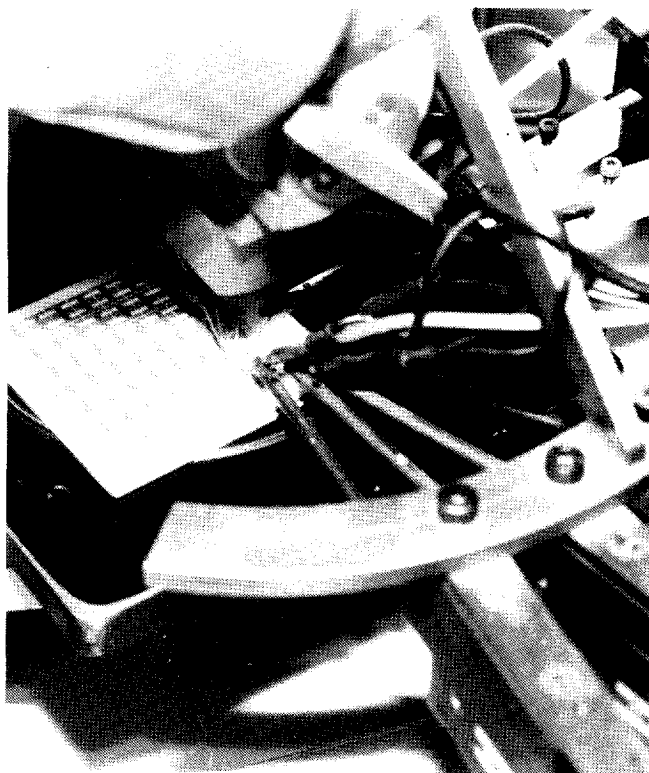

Thin film resistors screening

A wide range of products from DC – 1 GHz to DC – 46 GHz coupled with a long and successful experience in all aspects of research, production, inspection, and quality testing are extremely advantageous for meeting the needs of civilian and military professional markets (aeronautics, space exploration, radar, telecommunications and radio communications, instrumentation, and computer science).

COAXIAL COUPLERS

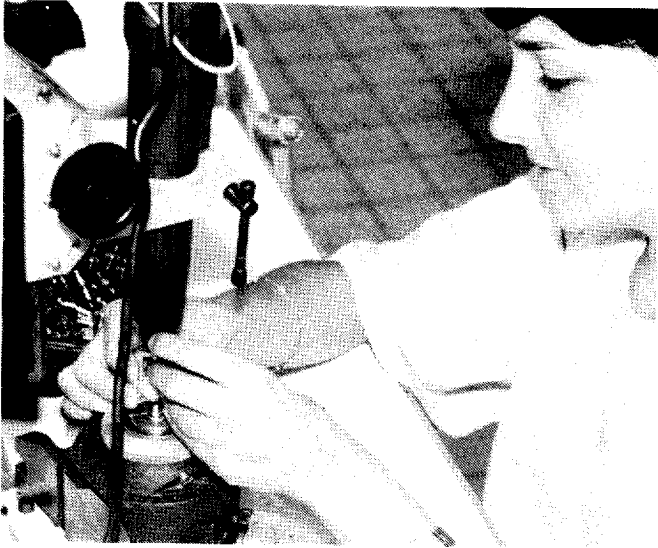

Termination assembly station

RADIALL microwave divisions components are marketed on an international sales network. Our subsidiaries and agents situated world – wide, are capable of providing technical solutions using a systematic approach to optimizing costs and services, for standard products as well as for development of optional and custom–built products.

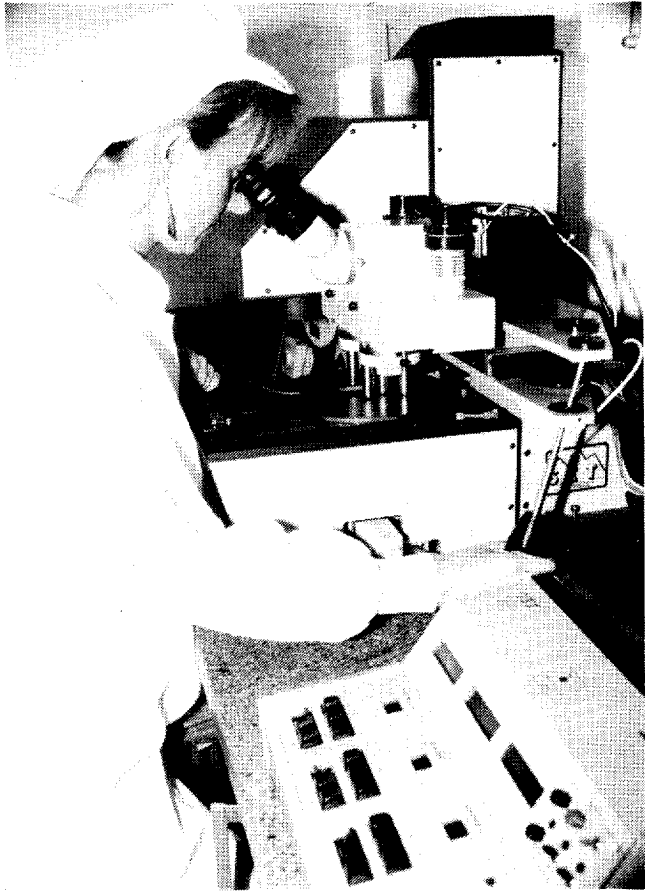

Thin film etching

Isle d'Abeau factory is rated **AQAP 4** by the **Quality Assurance** system in accordance with **NATO** requirements and procedures. The manufacture and quality testing of **ESA** – certified attenuators, terminations, and couplers have enabled **RADIALL** to participate for many years in all major European and international space programs. This fact testifies to the level of quality and reliability attained by the components produced by this division.

COAXIAL COUPLERS

3 – GENERAL SPECIFICATIONS

Designed to meet MIL C 15370, MIL P 23971 and MIL E 5400

3.1 ENVIRONMENTAL CHARACTERISTICS

SERIES	R 432070	R 433...	R 4329...
OPERATING TEMPERATURE RANGE (°C)	-25/+70	-40/+100	-40/+85
STORAGE TEMPERATURE RANGE (°C)	-25/+70	-40/+100	-55/+100
VIBRATION (MIL STD 202)	N/A	Method 204 Cond.D	
SHOCK (MIL STD 202)	N/A	Method 213 Cond.C	

3.2 MECHANICAL CHARACTERISTICS, MATERIALS AND FINISHES

CONSTRUCTION		SPLASHPROOF
RF BODY		Aluminium black painted
CONNECTORS	SMA	Stainless steel, Passivated
	TNC	Stainless steel, Passivated
	N	Brass, Nickel Plated

3.3 MANUFACTURING AND QUALITY ASSURANCE

RADIALL maintains a state of the art computer aided designed system, a well equipped precision machining factory, a modern component assembly area and an extensive collection of RF test (up to 40 GHz) and environmental test fixtures .

After assembly, each individual coupler is subjected to thermal cycling. This operation stabilizes the R performances and thus, assures trouble free RF performance drift during life (See FLOW CHART).

Special testing is available upon request.

COAXIAL COUPLERS

MANUFACTURING AND QUALITY ASSURANCE

Flow Chart (R 433 xxx Serie)

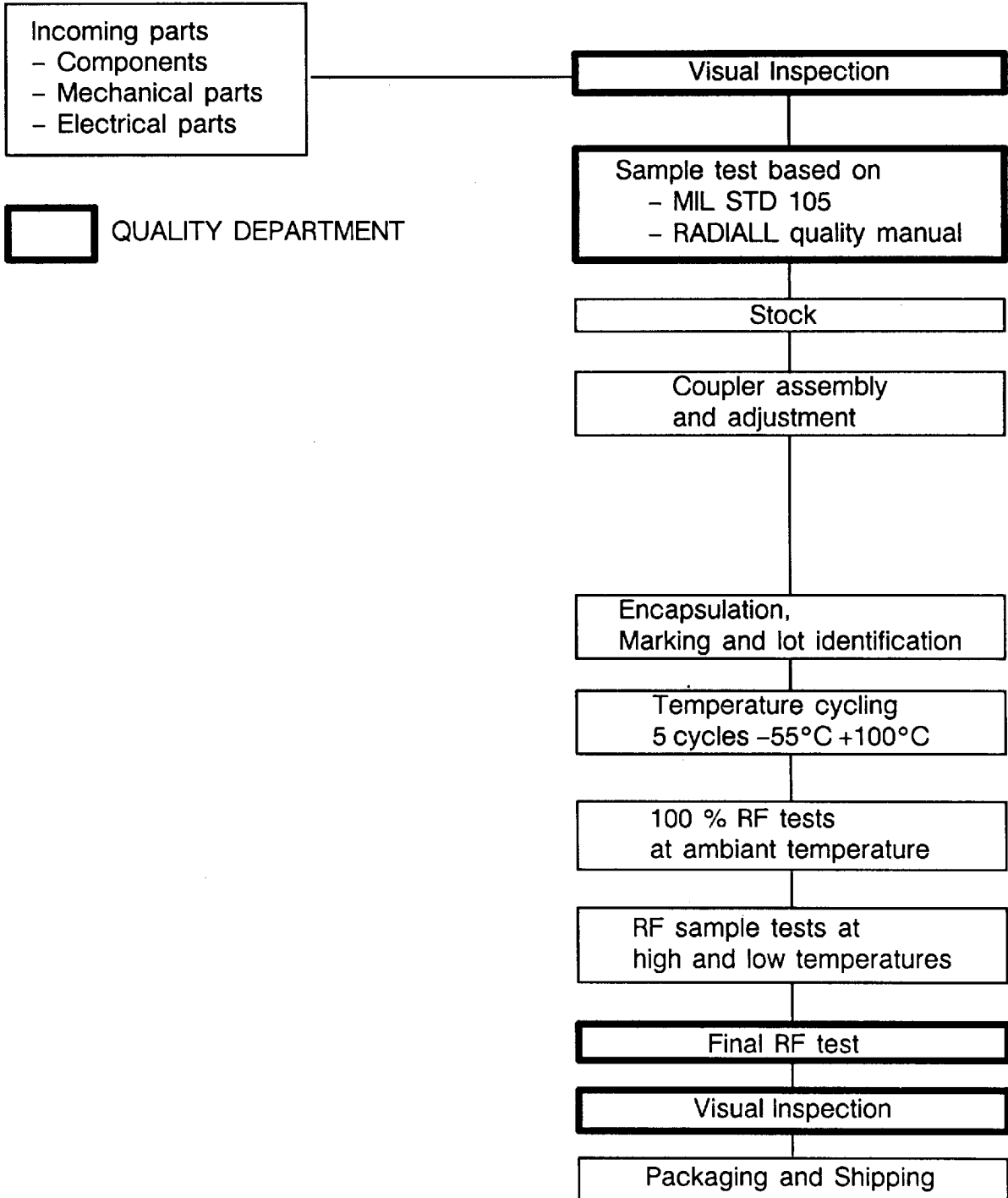

COAXIAL COUPLERS

4 – SELECTION GUIDE

3dB 90° HYBRID SMA COAXIAL COUPLERS (See page 14)

SERIES		R 433...
CONNECTORS		SMA
NOMINAL COUPLING (dB)		3
FREQUENCY RANGE (GHz)	7 – 12.4	R 433 721 700
	12.4 – 18	R 433 831 700
	6 – 18	R 433 611 700

FLAT RESPONSE UNIDIRECTIONAL COAXIAL COUPLERS (See page 16)

SERIES		R 433...		
CONNECTORS		SMA		
NOMINAL COUPLING (dB)		6	10	20
FREQUENCY RANGE (GHz)	2 – 18	–	R 433 503	–
	0.9 – 2.1	–	R 433 423	R 433 424
	1.7 – 4.2	–	R 433 523	R 433 524
	2 – 8	–	R 433 513 700	R 433 514 700
	7 – 12.4	–	R 433 723 700	R 433 724 700
	12.4 – 18	–	R 433 833 700	R 433 834 700
	6 – 18	R 433 612 700	R 433 613 700	R 433 614 700

COAXIAL COUPLERS

3dB 90° HYBRID HIGH POWER COAXIAL COUPLERS (See page 18)

SERIES		R 432..		
NOMINAL COUPLING (dB)		3		
CONNECTORS		SMA	N	TNC
FREQUENCY RANGE (GHz)	0.15 – 0.3	-	R 432 171 (500W)	-
	0.25 – 0.5	-	R 432 271 (500W)	-
	0.5 – 1	-	R 432 371 (300W)	-
	1 – 2	R 432 431 (100W)	R 432 471 (200W)	-
	6 – 18	-	-	R 432 986 (100W)

Note : () Average power (W)

UNIDIRECTIONAL HIGH POWER COAXIAL COUPLERS (See page 20)

SERIES		R 432...			
CONNECTORS		TNC / SMA			
NOMINAL COUPLING (dB)		30		40	
AVERAGE POWER (W)		100	400	100	400
FREQUENCY RANGE (GHz)	2 – 8	-	R 432 955	-	R 432 956
	6 – 18	R 432 957	R 432 967	R 432 959	R 432 969

COAXIAL COUPLERS

5 – CATALOG TERMS AND CHARACTERISTICS OF TECHNICAL DATA

DIRECTIONAL COUPLER

A directional coupler is a transmission-line component characterized physically by two (or three, for certain bidirectional couplers) juxtaposed transmission lines and an associated coupling structure through which a transfer of RF energy from one to the other is effected; its electrical behavior is characterized ideally by such interaction between the two lines that excitation in a single direction in either line produces a response in the companion line in one, direction only.

UNIDIRECTIONAL COUPLER

An unidirectional coupler is a directional coupler so designed as to provide a nominal response in the secondary line to propagation in the primary line, in one direction only.

BIDIRECTIONAL COUPLER

A bidirectional coupler is a directional coupler so designed as to provide separate and simultaneous nominal responses in the secondary lines to each of the two directions of propagation in the primary line.

PRIMARY LINE (MAIN LINE)

The primary line of a directional coupler is the line designed to receive the principal flow of RF energy in the transmission line to which the directional coupler is adjunct. The input end of the primary line of a unidirectional coupler is the end into which power must flow in order to produce the maximum power at the output of the secondary line. The other end is called the output (antenna) end.

SECONDARY LINE (COUPLED LINE)

The secondary line of a directional coupler is the line that is coupled to the primary line by means of the coupling structure. In a unidirectional coupler there is one secondary line. In a bidirectional coupler the secondary lines have a nominal response to a different direction of propagation in the primary line. In some bidirectional couplers the secondary lines are physically separate; in others they run physically together.

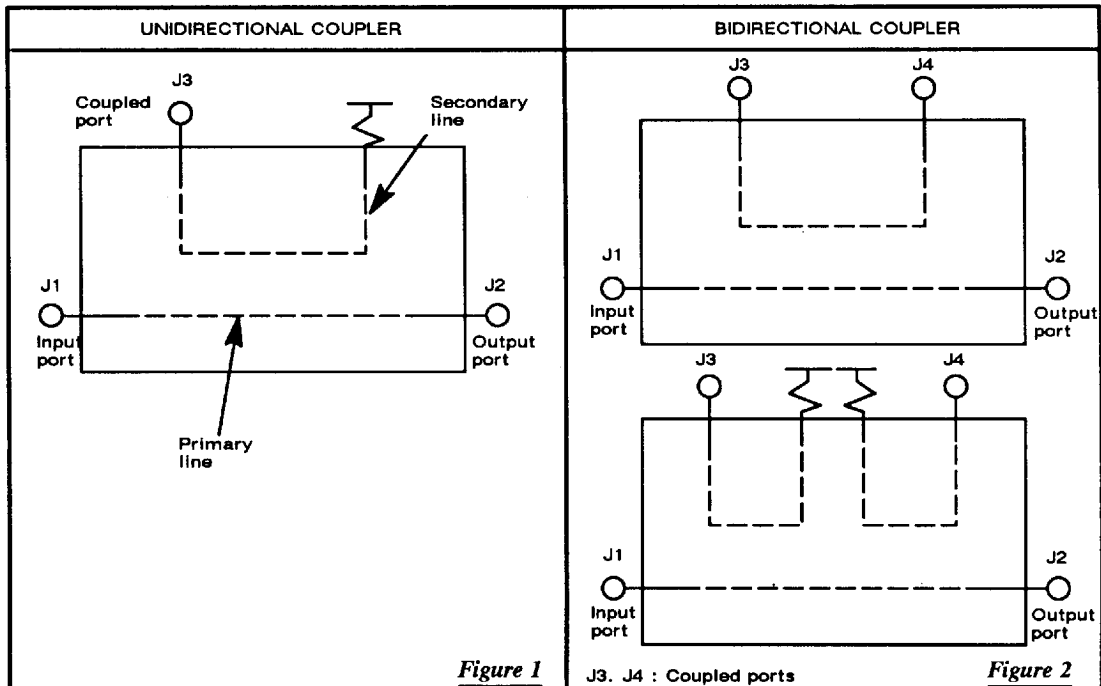

COAXIAL COUPLERS

3 dB 90° HYBRID COUPLER

Hybrid or hybrid couplers are basically 3 dB directional couplers in which the phase of the coupled output signal and the output signal are 90° apart.

Since -3 dB represents half power, a 3 dB coupler divides the power equally (within a certain tolerance) between the output and coupled output ports. Ninety degree hybrids are also called quadrature hybrids because the phase of the two outputs is a quadrant (90°) apart.

RADIALL 3dB 90° Hybridcoupler are crossover configuration and has both the direct output and the coupled output ports on the same side of the coupler.

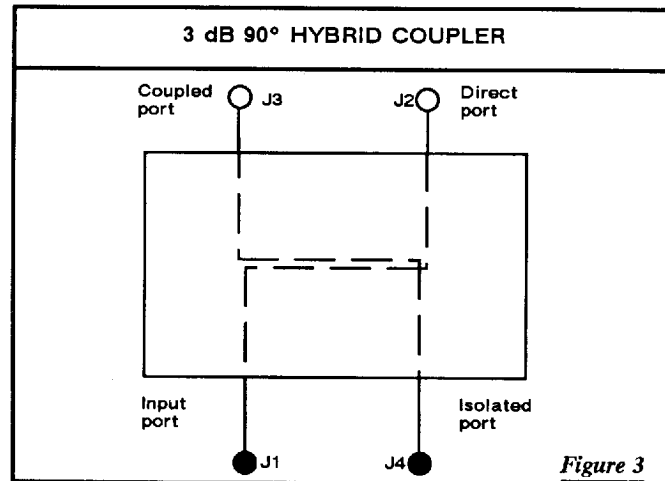

RF CONNECTORS

RF connectors are 50 ohm, unless otherwise specified. The applicable mating dimensions, materials and finishes are in accordance with applicable sections of MIL C 39012.

RF CHARACTERISTICS

Typical measured values (max. or min. only where specified)

VSWR

The impedance discontinuity when the coupler is inserted into a matching line (50 ohms for most RADIALL products) and all ports terminated with a matching load.

The ratings in this catalog are for the coupler only, and do not include the VSWR of adaptors used to connect the coupler to circuits or test device.

COUPLING

The coupling of directional couplers is determined by obtaining the midpoint between the maximum and minimum coupling over the specified frequency range. The coupling of unidirectional couplers is determined as the ratio, expressed in dB, of the power input to the primary line to the power available at the output of the secondary line, with the output end of the primary line properly terminated. The coupling of bidirectional couplers is determined separately for each secondary line.

$$\text{Coupling (dB)} = -10 \text{ Log} \left(\frac{P_{(J1)}}{P_{(J3)}} \right)$$

COAXIAL COUPLERS

FREQUENCY SENSITIVITY (COUPLING VARIATION)

The frequency sensitivity of directional couplers is determined over the specified frequency range. The coupling variation of unidirectional couplers is determined by taking the difference between the maximum and the minimum coupling over the specified frequency range. Such difference is taken as a positive number or zero. The coupling variation of bidirectional couplers is determined separately for each secondary line.

INSERTION LOSS

(See figure 1,2)

DIRECTIONAL COUPLER

The difference in the power level received at the load before and after the insertion of the primary line of the coupler in a transmission line. Insertion loss is measured in decibels below the input power.

$$\text{Insertion loss (dB)} = 10 \text{ Log} \left(\frac{P(J2)}{P(J1)} \right)$$

In an ideal dissipationless coupler, the main line loss (J1-J2) due to power coupled to the coupled output port is :

$$\text{Insertion loss (dB)} = 10 \text{ Log} \left(1 - \frac{P(J3)}{P(J1)} \right)$$

The effect of dissipation in the circuit will be to raise the insertion loss by the power dissipation in dB. A graph of the theoretical insertion loss (dB) vs coupling (dB) for a dissipationless coupler is shown below.

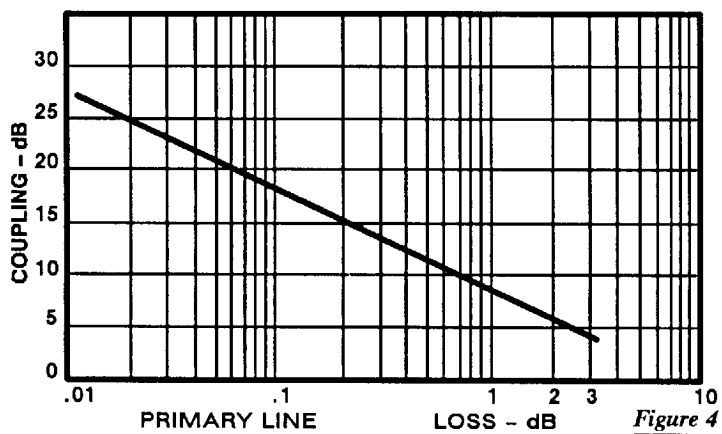

HYBRID COUPLER

(See figure 3)

The insertion loss is determined by subtracting the nominal value of the divider (3dB) from the measured average coupling value.

The average coupling of the item is determined by the swept frequency technique over the specified frequency range. It is the average of the measured coupling between the input port and each output port.

DIRECTIVITY

Directivity of directional coupler is defined over the specified frequency range. The directivity of unidirectional couplers shall be computed from the ratio, taken as greater than unity and expressed in dB, of the available power at the output of the secondary line for the two directions of excitation, at equal power levels, of the primary line; the secondary line shall be terminated in a matched detector.

$$\text{Directivity (dB)} = - 10 \text{ Log} \left(\frac{P(J4)}{P(J3)} \right)$$

COAXIAL COUPLERS

Where power is incident to port 1. The terms $P(J4)$ and $P(J3)$ represent the power at ports J4 and J3 respectively. The negative sign in the equation results in the directivity always being a positive number.

The directivity of bidirectional couplers shall be determined separately for each secondary line.

ISOLATION

The isolation is measured between any selected input port and adjacent isolated port with the opposite output ports terminated with matched loads, across the full frequency range.

$$\text{Isolation (dB)} = -10 \text{ Log} \left(\frac{P(J4)}{P(J1)} \right)$$

Where $P4$ and $P1$ are the power levels at ports 4 and 1 respectively. Isolation and directivity measure the same characteristic.

$$\text{Isolation (dB)} = \text{Coupling (dB)} + \text{Directivity (dB)}$$

For example, a 10 dB coupler with 20 dB directivity would have 30 dB isolation. Directivity, rather than isolation, is usually specified on directional couplers. For 3 dB hybrid couplers, isolation is usually specified.

AMPLITUDE BALANCE (3 dB HYBRID COUPLER ONLY)

The amplitude balance is the difference measured between the two output ports with the adjacent nobled port terminated with matched load, across the full frequency range, with respect to the average coupling value. The limit is expressed as $\pm x$ dB as to allow a maximum difference of $2x$ dB.

PHASE BALANCE

The phase balance of the hybrid coupler is measured between the output ports with the other co-linear output port and the adjacent isolated port terminated in matched loads.

AVERAGE POWER

The RF power rating is the capability of handling RF power (CW power) through main line of the coupler. Power ratings assume unity VSWR (matched load), at room temperature (20°C) and sea level pressure (14.7 p.s.i.). See the CW power capability Vs. Frequency Chart. Change in these specifications require power derating (see derating factor versus VSWR figure 5).

Higher power ratings can be achieved by using Heat Conducting Insulation. RADIALL couplers with TNC connectors are recommended for high average power applications up to 18 GHz.

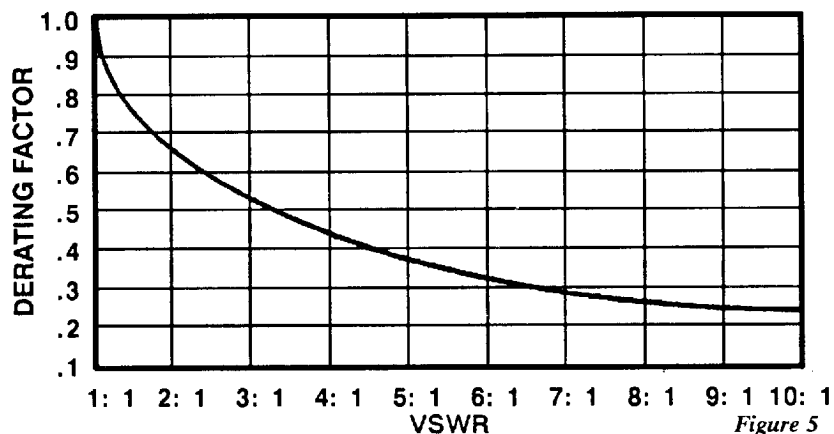

Figure 5

The power rating of a coupler must be reduced for circuit VSWR above 1:1.

COAXIAL COUPLERS

6 – PRODUCTS

6.1 – 3 dB 90° HYBRID SMA COAXIAL COUPLERS

RF CHARACTERISTICS

RADIALL PART NUMBER	FREQUENCY RANGE (GHz)	AMPLITUDE BALANCE (dB)	INSERTION LOSS (dB) (max)	ISOLATION (dB) (mini)	VSWR (max) (dB)	INPUT POWER		FIGURE
						AVERAGE (W) (1)	PEAK (KW) (2)	
R 433 721 700	7 – 12.4	± 0.5	0.4	18	1.35	30	3	1
R 433 831 700	12.4 – 18	± 0.7	0.6	16	1.40	30	3	1
R 433 611 700	6 – 18	± 0.6	0.6	15	1.50	30	3	1

Notes : (1) at 25°C
(2) at 25°C (1µs – duty cycle 1%)

MECHANICAL CHARACTERISTICS

CONSTRUCTION	SPLASHPROOF
RF CONNECTORS	SMA per MIL C 39012

ENVIRONMENTAL CHARACTERISTICS (In accordance with MIL STD 202)

OPERATING TEMPERATURE RANGE	-40/+100°C
STORAGE TEMPERATURE RANGE	-40/+100°C
VIBRATION (MIL STD 202)	METHOD 204 cond D (10–2000/20G)
SHOCK (MIL STD 202)	METHOD 213 cond C (100G/6mS)

COAXIAL COUPLERS

OUTLINE DRAWINGS

GENERAL TOLERANCE ± 0.5 mm

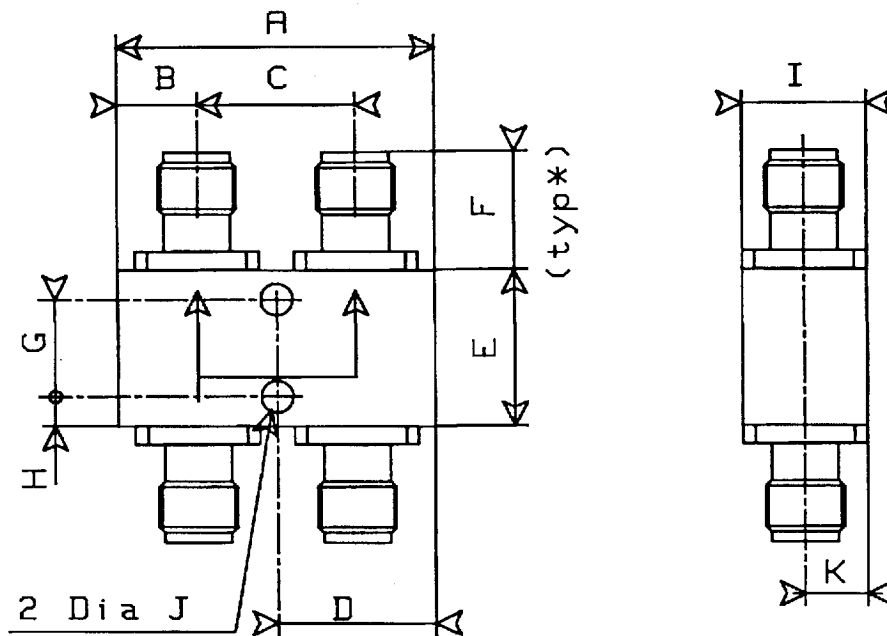

4 SMA/f connectors

Fig. 1

A	25.4
B	6.35
C	12.7
D	12.7
E	12.7
F	9.5
G	7.9
H	2.4
I	10
J	2.6
K	5
WEIGHT (g)	25

COAXIAL COUPLERS

6.2 FLAT RESPONSE DIRECTIONAL COAXIAL COUPLERS

RF CHARACTERISTICS

RADIALL PART NUMBER	FREQUENCY RANGE (GHz)	COUPLING (dB)	FREQUENCY SENSITIVITY \pm (dB) (5)	INSERTION LOSS (dB) (max)	DIRECTIVITY (dB)	VSWR	INPUT POWER		FIGURE
							AVERAGE (W) (1)	PEAK (kW) (2)	
R 433 423	0.9 - 2.1	10 \pm 0.8	0.3	1	22	1.15	50	3	5
R 433 424		20 \pm 0.8	0.3	0.4	22	1.15	50	3	5
R 433 523	1.7 - 4.2	10 \pm 0.8	0.3	1	20	1.20	50	3	1
R 433 524		20 \pm 0.8	0.3	0.4	20	1.20	50	3	1
R 433 513 700	2 - 8	10 \pm 1	0.4	1	20	1.25	50	3	2
R 433 514 700		20 \pm 1	0.4	0.4	20	1.25	50	3	2
R 433 723 700	7 - 12.4	10 \pm 1	0.5	1	16	1.30	50	3	3
R 433 724 700		20 \pm 1	0.5	0.4	16	1.30	50	3	3
R 433 833 700	12.4 - 18	10 \pm 1	0.5	1.1	15	1.35	50	3	3
R 433 834 700		20 \pm 1	0.5	0.55	15	1.35	50	3	3
R 433 612 700	6 - 18	6 \pm 1	0.5	2.2	15	1.40	50	3	3
R 433 613 700		10 \pm 1	0.5	1.1	16	1.40	50	3	3
R 433 614 700		20 \pm 1	0.5	0.6	15	1.40	50	3	3
R 433 503	2 - 18	10 \pm 1	\pm 0.6	1.4	15 (3)	1.35/1.50 (4)	20	3	4

- Notes :
- (1) at 25°C
 - (2) at 25°C (1 μ s - duty cycle 1%)
 - (3) 12 dB from 12.4 GHz up to 18 GHz
 - (4) main line / coupled line .
 - (5) Frequency sensitivity included in coupling .

MECHANICAL CHARACTERISTICS

CONSTRUCTION	SPLASHPROOF
RF CONNECTORS	SMA per MIL C 39012

ENVIRONMENTAL CHARACTERISTICS (In accordance with MIL STD 202)

OPERATING TEMPERATURE RANGE	MODELS R 433 xxx 700	-40°C/+100°C
	MODELS R433 xxx	-25°C/+85°C
STORAGE TEMPERATURE RANGE	-40°C/+100°C	
VIBRATION (MIL STD 202)	METHOD 204 cond D (10-2000/20g)	
SHOCK (MIL STD 202)	METHOD 213 cond C (100G/6mS)	

COAXIAL COUPLERS

OUTLINE DRAWINGS

GENERAL TOLERANCE ± 0.5 mm

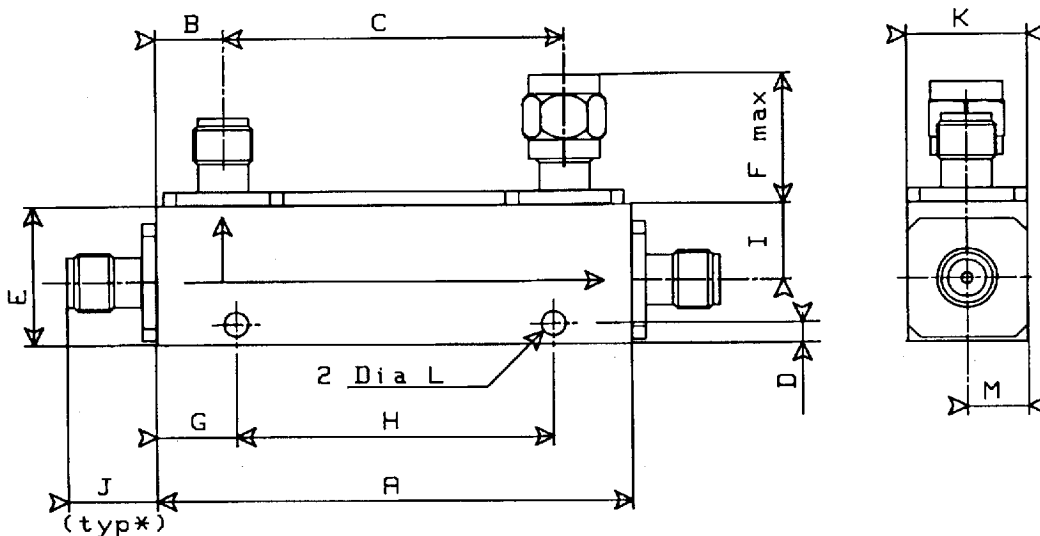

3 SMA/f connectors

	FIG.1	FIG.2	FIG.3	FIG.4	FIG.5
--	-------	-------	-------	-------	-------

A	50.8	45.3	25.6	50.8	79
B	7.2	7.45	6.45	6.7	6.5
C	36.5	30.4	12.7	37.4	66
D	2.2	2.2	2.2	2.2	2.2
E	15	15	15	15	20
F	17	17	17	17	17
G	8.4	11.65	12.8	8.4	22.5
H	34	22	--	34	34
I	8.2	8.2	8.2	8.2	13.3
J	9.5	9.5	9.5	9.5	9.5
K	13	10	10	13	13
L	2.6	2.6	2.6	2.6	2.6
M	6.5	5	5	6.5	6.5
WEIGHT (g)	50	40	30	50	65

COAXIAL COUPLERS

6.3 3 dB 90° HYBRID HIGH POWER COAXIAL COUPLERS

RF CHARACTERISTICS

RADIALL PART NUMBER	FREQUENCY RANGE (GHz)	AMPLITUDE BALANCE ± (dB)	INSERTION LOSS (dB) (max)	ISOLATION (dB) (min)	VSWR (max) (dB)	INPUT POWER		FIGURE
						AVERAGE (W) (1)	PEAK (kW) (2)	
R 432 171	0.15 – 0.3	0.5	0.3	30	1.15	500	5	1
R 432 271	0.25 – 0.5	0.5	0.3	30	1.15	500	5	2
R 432 371	0.5 – 1	0.5	0.3	25	1.15	300	5	3
R 432 471	1 – 2	0.5	0.3	25	1.20	200	5	4
R 432 431	1 – 2	0.5	0.3	25	1.20	100	3	5
R 432 986	6 – 18	0.75	0.8	12	1.75	100	5	6

Notes : (1) at 25°C
(2) at 25°C (1µs - duty cycle 1%)

MECHANICAL CHARACTERISTICS

CONSTRUCTION		SPLASHPROOF
RF Connectors (MIL C 39012)	R 432 171	N
	R 432 271	N
	R 432 371	N
	R 432 471	N
	R 432 431	SMA
	R 432 986	TNC

ENVIRONMENTAL CHARACTERISTICS (In accordance with MIL STD 202)

	N AND SMA CONNECTORS	TNC CONNECTORS
OPERATING TEMPERATURE RANGE	-25/+70	-40/+85
STORAGE TEMPERATURE RANGE	-25/+70	-55/+100
VIBRATION (MIL STD 202)	METHOD 204 cond D (10-2000/20G)	
SHOCK (MIL STD 202)	METHOD 213 cond C (100G/6mS)	

COAXIAL COUPLERS

OUTLINE DRAWINGS

GENERAL TOLERANCE ± 0.5 mm

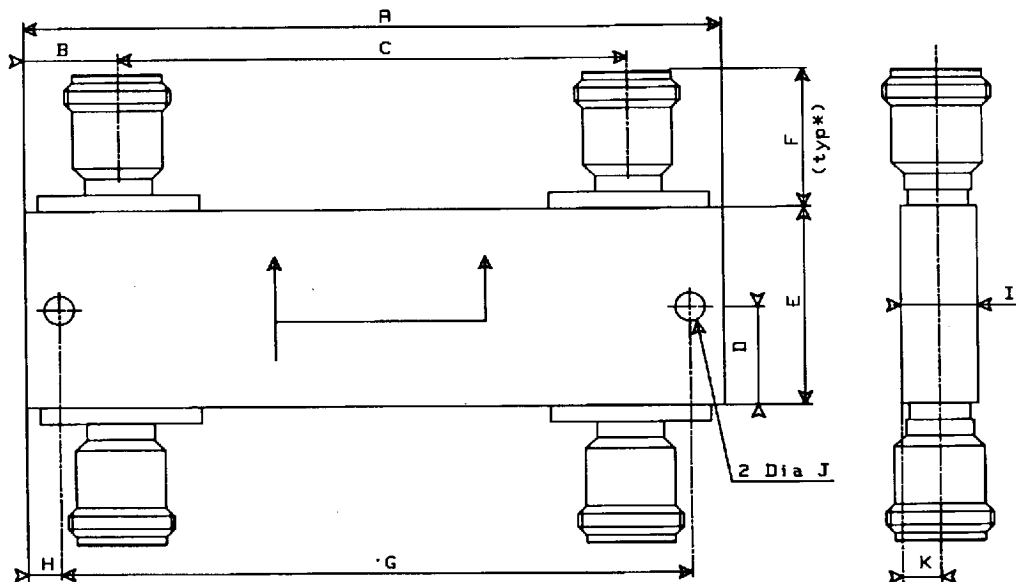

4 female connectors

	FIG.1	FIG.2	FIG.3	FIG.4	FIG.5	FIG.6
--	-------	-------	-------	-------	-------	-------

A	240	156	93	58.7	49	35
B	14	14	14	13.6	8	7.9
C	212	128	65	31.5	33	19.3
D	15.2	15.2	15.2	15.2	10.5	13.5
E	30.4	30.4	30.4	30.4	21	27
F	21.7	21.7	21.7	21.7	7.4	12
G	230	146	83	52	42	29
H	5	5	5	3.4	3.5	3
I	11.3	11.3	11.3	11.3	8.3	14.3
J	4.4	4.4	4.4	3.3	3.3	3.5
K	5.65	5.65	5.65	5.65	4.15	7.15
WEIGHT (g)	510	370	260	210	60	62

COAXIAL COUPLERS

6.4 DIRECTIONAL HIGH POWER COAXIAL COUPLERS

RF CHARACTERISTICS

RADIALL PART NUMBER	FREQUENCY RANGE (GHz)	COUPLING (dB)	FREQUENCY SENSITIVITY ± (dB)	INSERTION LOSS (dB)	DIRECTIVITY (dB)	VSWR	INPUT POWER		FIGURE
							AVERAGE (W) (1)	PEAK (KW) (2)	
R 432 957	6-18	30 ± 1	1	0.5	15	1.30/1.40	100	2.5	1
R 432 959	6-18	40 ± 1	1	0.5	15	1.30/1.40	100	2.5	1
R 433 955	2-8	30 ± 1	0.5	0.25	16	1.30/1.40	300	2.5	2
R 433 956	2-8	40 ± 1	0.5	0.25	16	1.30/1.40	300	2.5	2
R 433 967	6-18	30 ± 1	0.7	0.5	12/10 (3)	1.40/1.60	400	3	3
R 433 969	6-18	40 ± 1	0.7	0.5	12/10 (3)	1.40/1.60	400	3	3

Notes : (1) at 25°C
 (2) at 25°C (1µs-duty cycle 1%)
 (3) 6-15GHz/15-18GHz
 (4) main line/coupled line

MECHANICAL CHARACTERISTICS

CONSTRUCTION	SPLASHPROOF
RF CONNECTORS	SMA PER MIL C 39012

ENVIRONMENTAL CHARACTERISTICS (In accordance with MIL STD 202)

OPERATING TEMPERATURE RANGE	-40/+85°C
STORAGE TEMPERATURE RANGE	-55/+100°C
VIBRATION (MIL STD 202)	METHOD 204 cond D (10-2000/20G)
SHOCK (MIL STD 202)	METHOD 213 cond C (100G/6mS)

COAXIAL COUPLERS

OUTLINE DRAWINGS

GENERAL TOLERANCE ± 0.5 mm

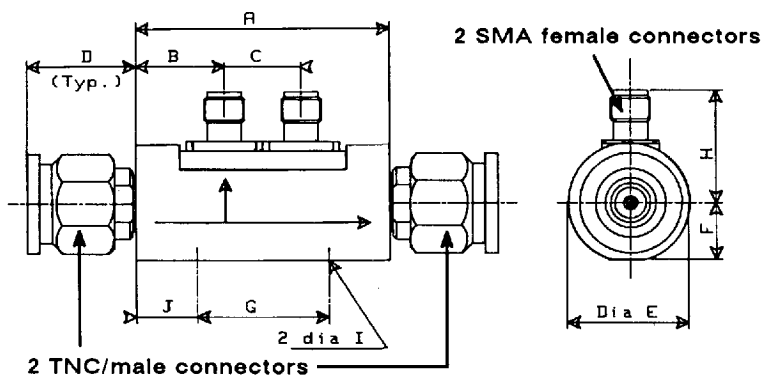

FIGURE 1

FIG.1

A	39
B	14
C	11.6
D	17.5
E	19
F	9
G	20.6
H	18
I	M 3 ISO Depth 3.5
J	9.2

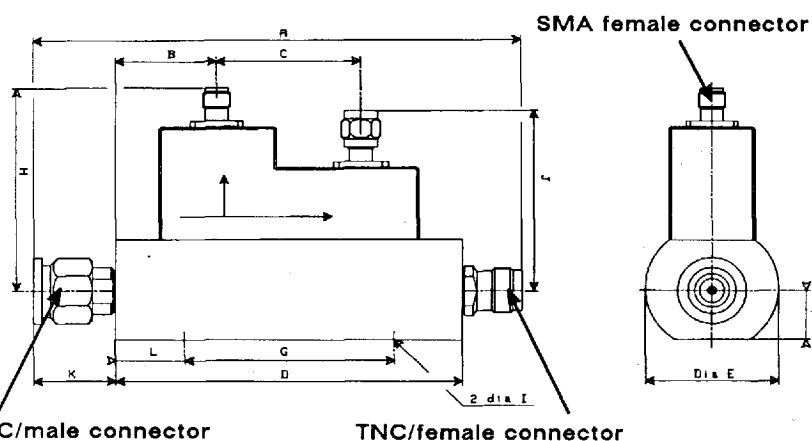

FIGURE 2

FIGURE 3

FIG.2

FIG.3

A	146	113.5
B	25.7	23.3
C	62.6	33
D	114	79.6
E	30	30
F	11.9	11.9
G	76.2	48.4
H	41.8	50
I	M 5 ISO Depth 5	M 5 ISO Depth 5
J	53	43.8
K	17.5	19
L	18.9	15.6

COAXIAL COUPLERS

SPACE QUALIFIED COAXIAL COUPLERS

More than 7500 space qualified components have been delivered for use in world wide space programs since 1975. These high reliability products have been approved and fully qualified by European Space Agency or International space customers.

HIGH RELIABILITY SPACE PROGRAMS USING RADIALL COUPLERS
ULYSSES SPOT I.II ITALSAT TELECOM I.II GIOTTO

RADIALL Series are SMA connector 3dB Power dividers are fully qualified by ESA under specification SCC 3404 (qualification certificate N°135). Unidirectional couplers are qualified by International Space Customers, E.S.A. qualification in progress.

A one thousand square foot limited access laboratory is used exclusively for the assembly and test of all space components. Clean rooms are used through out the assembly and inspection process to assure cleanliness.

Operators and inspectors are trained and regularly in-house re-qualified to verify adherence to stringent process control requirements.

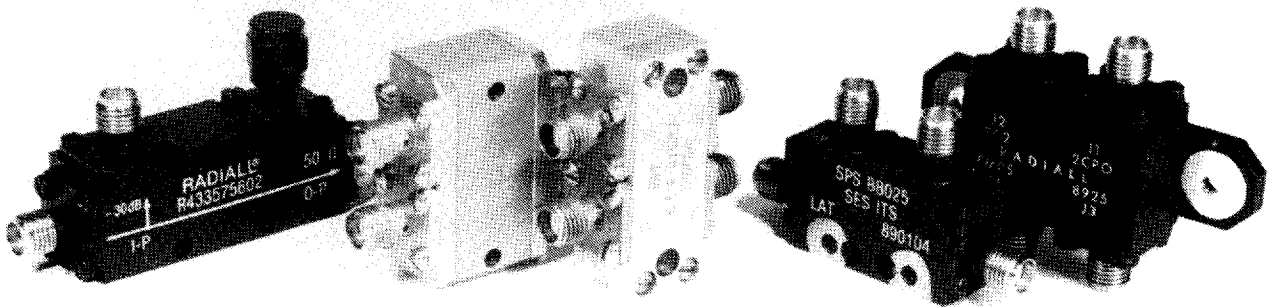

High Reliability space couplers

COAXIAL COUPLERS

7 – SPECIAL COUPLER DESIGNS AND CONFIGURATIONS

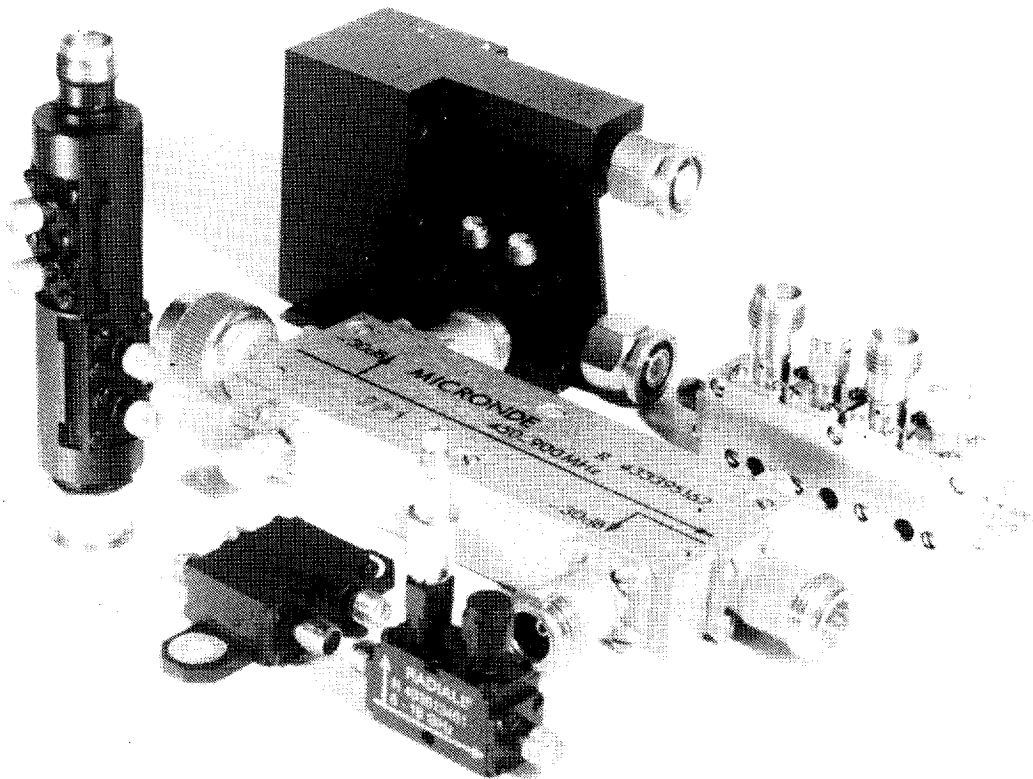

COAXIAL COUPLERS

CUSTOM COUPLERS

The following are just a few of the examples of custom couplers designed to a customer's specific requirement. Simply fill out custom card with your non-standard design requirement at the end of this handbook, a sales engineer will be glad to help.

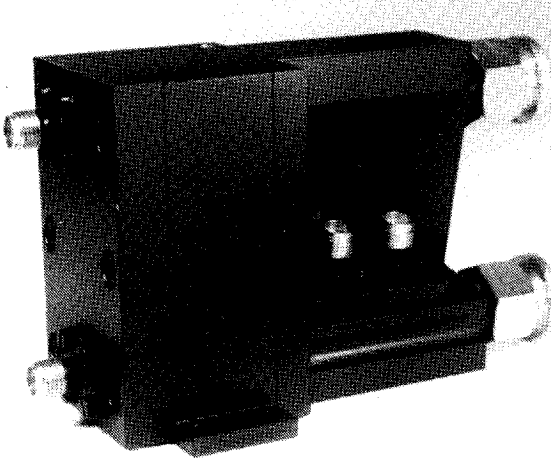

This 3 dB and 2 x 20 dB coupler can withstand 200 watts up to 18 GHz. It was developed for use in a classified military airborne Electronic Warfare Equipment.

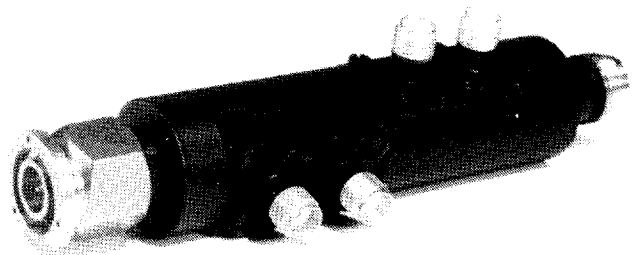

This double unidirectional coupler can handle 100 Wcw up to 100°C. This compact product is designed to use in a classified military airborne E.C.M. system.

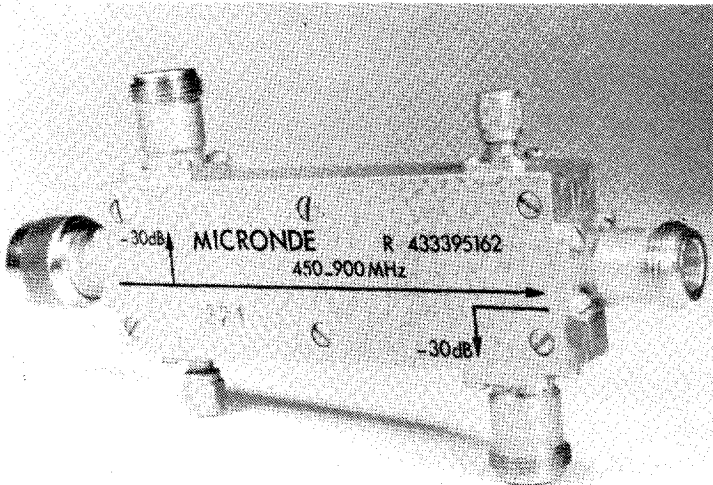

This bidirectional coupler was developed to control Antenna Power signals in a Television Transmitter.

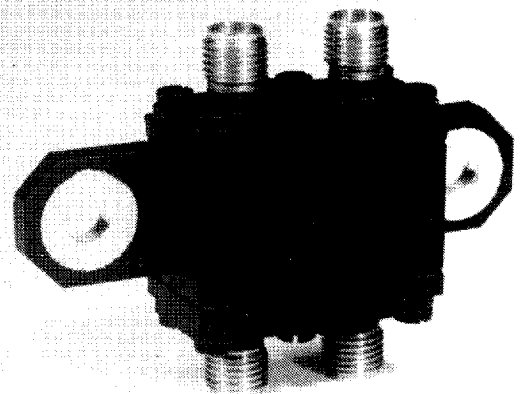

This 3.7 – 4.2 GHz 3dB hybrid coupler was developed for use in a ground base satellite station.

COAXIAL COUPLERS

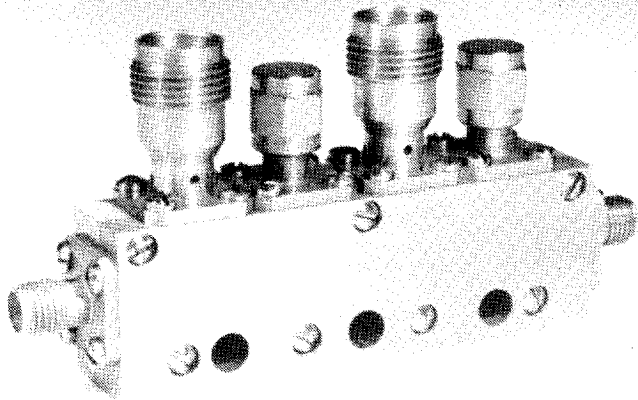

This double unidirectional coupler was designed to reduce insertion loss on main line. This product was developed to use in a very compact military equipment.

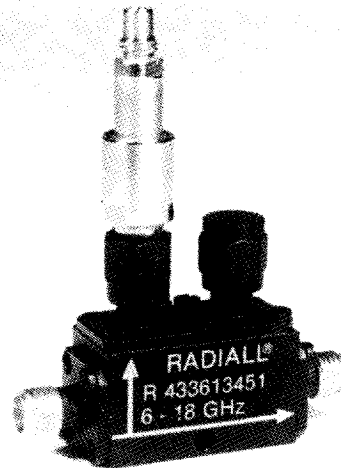

This 6 – 18 GHz coupler with a detected coupled output is designed for use in a test instrument. This product allows to control R.F. signals in a narrow frequency range.

RADIALL PRODUCT RANGE

COAXIAL CONNECTORS DC-46 GHz

- **Microminiature**
MMS - MCX - SSMB - SSMA - SBMA
- **Subminiature**
SMB - SMC - SMZ - SMZ lock - 1.0/2.3 - SMA - SMA 2.9 - BMA - PCB cable terminals
- **Miniature**
BNC 50 Ω , 75 Ω and commercial
TNC 50 Ω , 75 Ω and commercial - TNC 18 GHz
MiniQuick - 1,6/5,6 - Twinax - Triax
- **Standard**
N 50 Ω and 75 Ω - N 18 GHz
C - LC - HN - HN2 - UHF - UHF2 - 7/16
- **High Voltage**
- **Coaxial adaptors**
- **Accessories and assembly tools**
- **RF cable assemblies**
SHF low loss cable assemblies

MICROWAVE COMPONENTS from DC up to 40 GHz

- **Coaxial terminations**
- **Coaxial attenuators**
- **Coaxial couplers**
- **Coaxial and waveguide switches**
- **Detectors**
- **Other coaxial components**

RADIALL PRODUCT RANGE

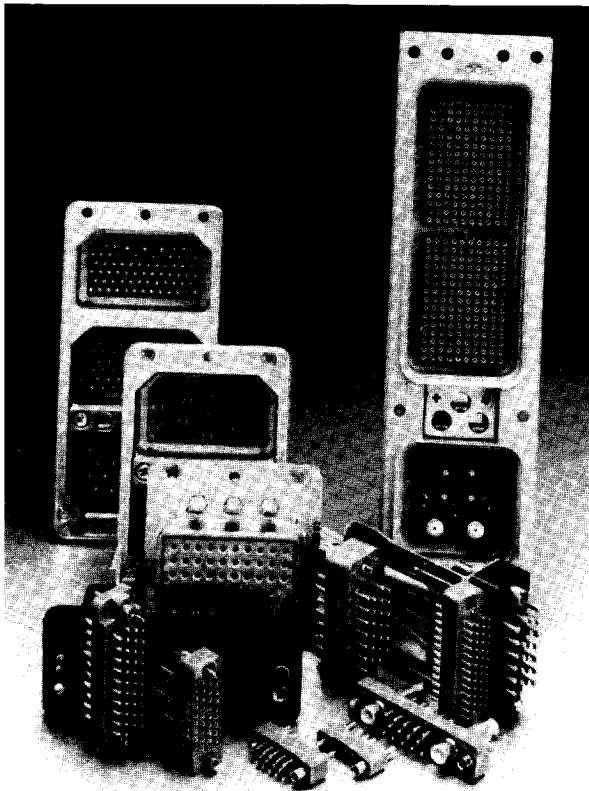

MULTIPIN CONNECTORS

- **Rack and panel rectangular connectors**
EPX
NSX - ARINC 600
DSX - ARINC 404, MIL-C-81659B/QPL
MPX - MIL-C-83527A, AECMA Pr EN3682
MMC - MIL-C-28748
- **Miniature and subminiature rectangular connectors**
M, MM, MB - MIL-C-28748
MBC
- **Professional banana plugs, sockets and cable assemblies**
Ø 2 mm - Ø 4 mm - safety type

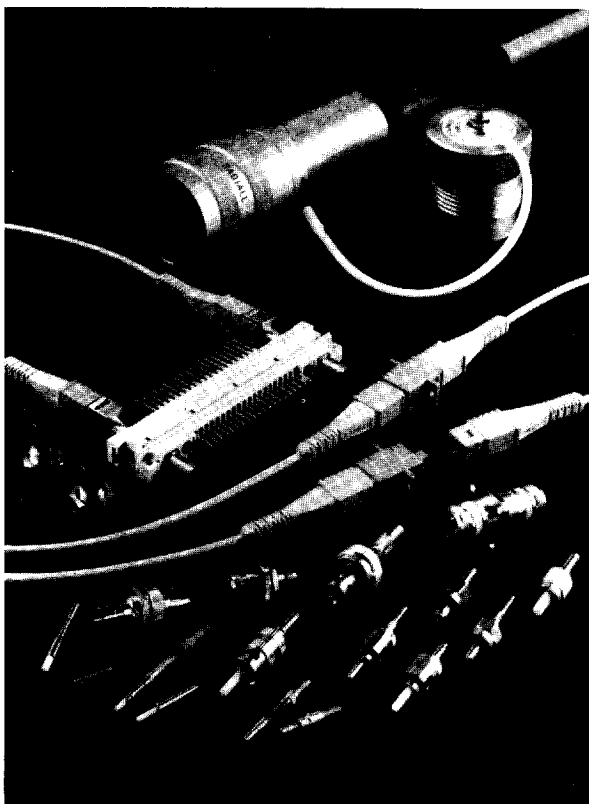

FIBER OPTIC COMPONENTS

- **Connectors for multimode fiber**
Standard connectors, bonded/polished installation :
– F-SMA, F 709 ST® compatible, BeST ST® compatible, MFO-S
Connector with push-pull locking system :
– EC*
"OPTABALL" adjustable connectors :
– PFO, MFO
Fast and easy connecting system :
– SFO : for 200 and 600 µm PCS fiber
– "FAST" series (F 709, F-SMA) : connectors with
cleaving system for all silica fibers 125-140 µm
- **Connectors for singlemode fiber**
High performance connectors, low loss, low reflection :
– EC*, with push-pull locking system
– VFO, OPTABALL adjustable system
– MP, for polarization maintaining fibers
- **Special connectors for military applications or harsh environment :**
– MILFO (singleway connector)
– F 742 (2 to 8 channels)
– TERMINI, optical contacts for rectangular and
cylindrical multipin connectors (MIL-C-83723, MIL-C-38999, etc.)
- **Optical contacts for back-panel connectors**
– MFO-S D/DR for multimode fiber
– EC* for singlemode fiber

*EC, design in the frame of the RACE program (Research and Development in Advanced Technologies in Europe) programm.